

SUPPLIED FIXING KIT – DM521

DESC	QTY
M8X20mm BOLT	8
M8 NYLOC NUT	8
M8 WASHER	16
M6 WASHER	4
M6X20mm BOLT	4

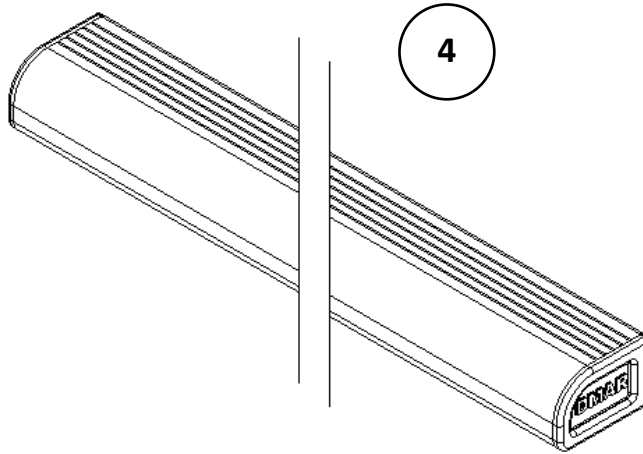

SUPPLIED COMPONENTS

#	DESC	QTY
1	RRP77	4
2	RRP129	4
3	25mm FOAM	480mm
4	D BAR	2

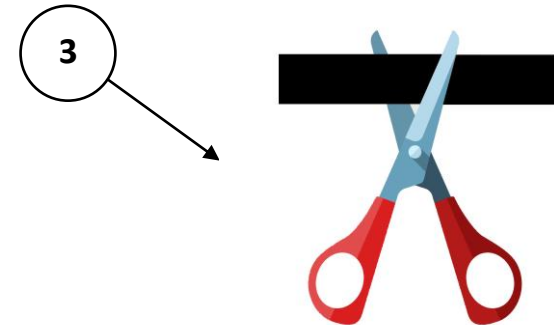
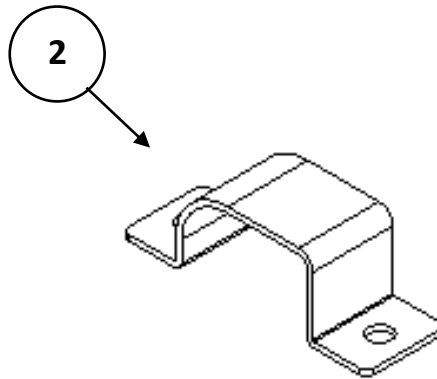
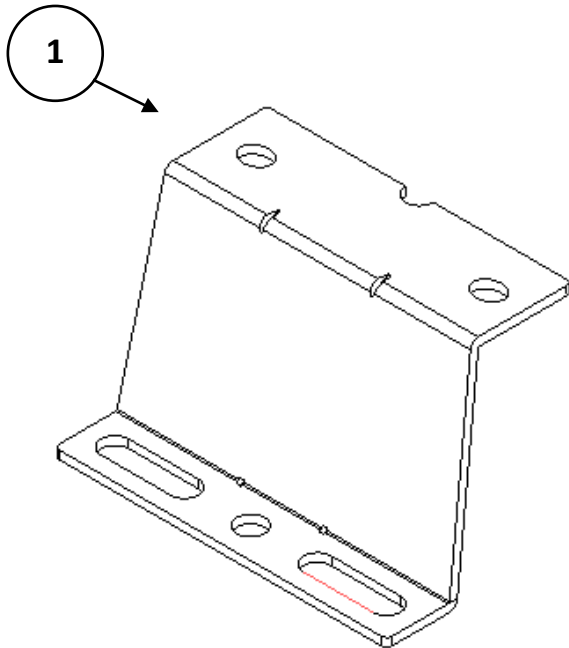

Cut the foam to length and stick to the bottom of the RRP77. Then, pierce through central hole.

Bolt the RRP129 to the top of the RRP77.
Leave all nuts finger tight at the moment.

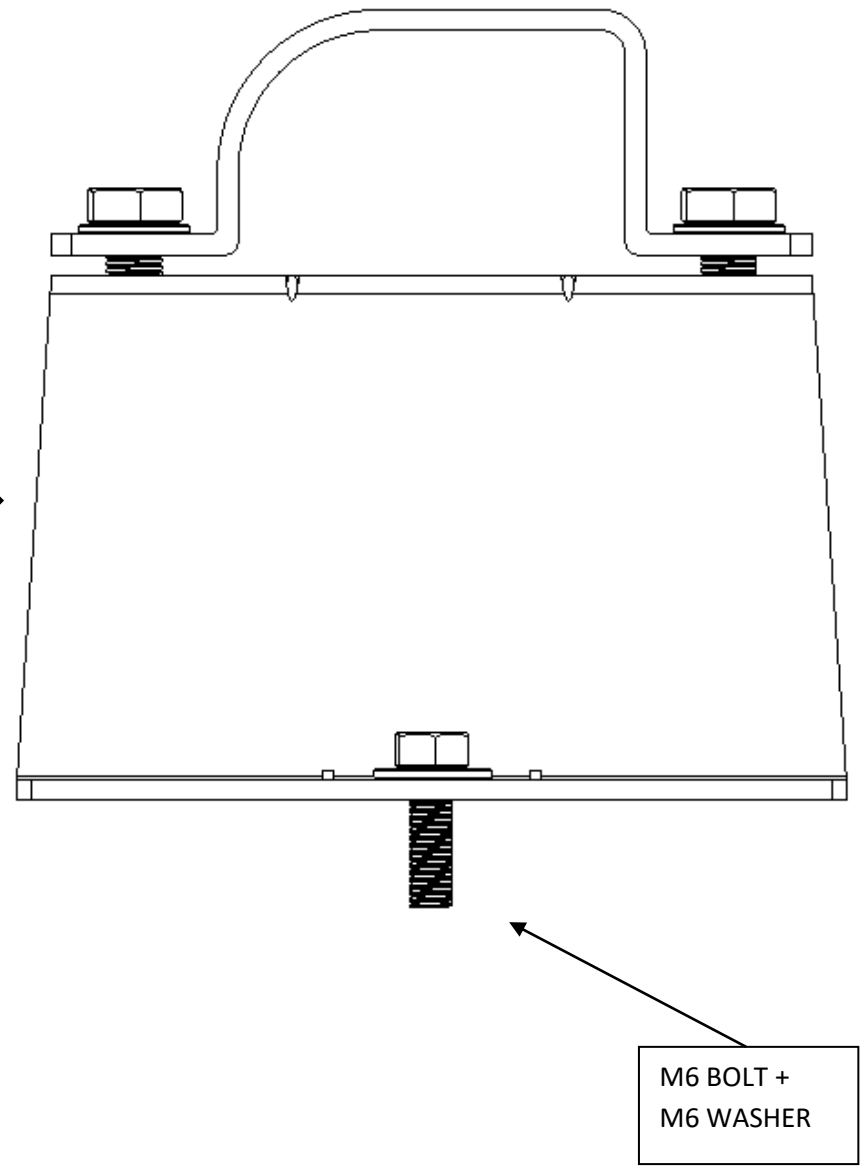
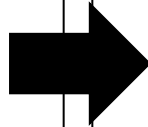
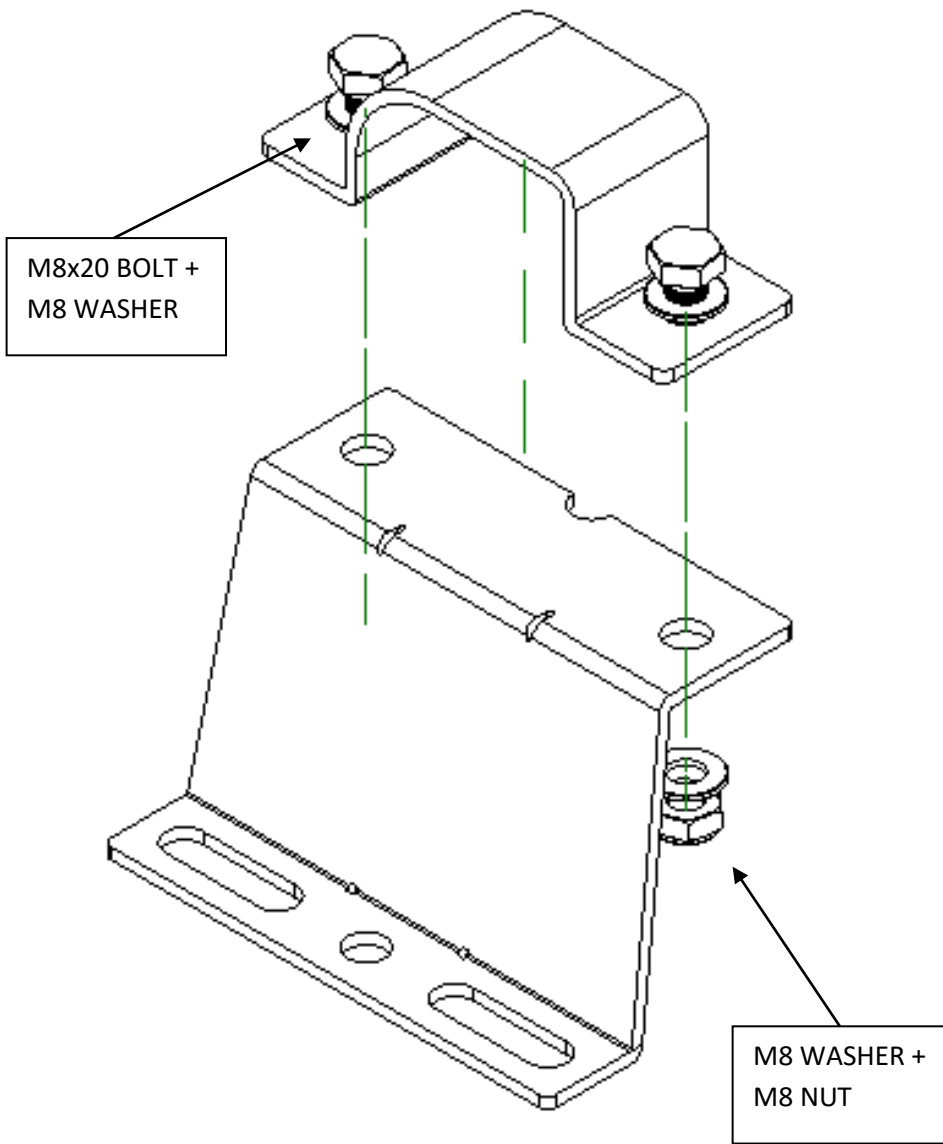

Slide the bar into place and make sure it is centrally positioned. At this stage, all nuts and bolts can be tightened.

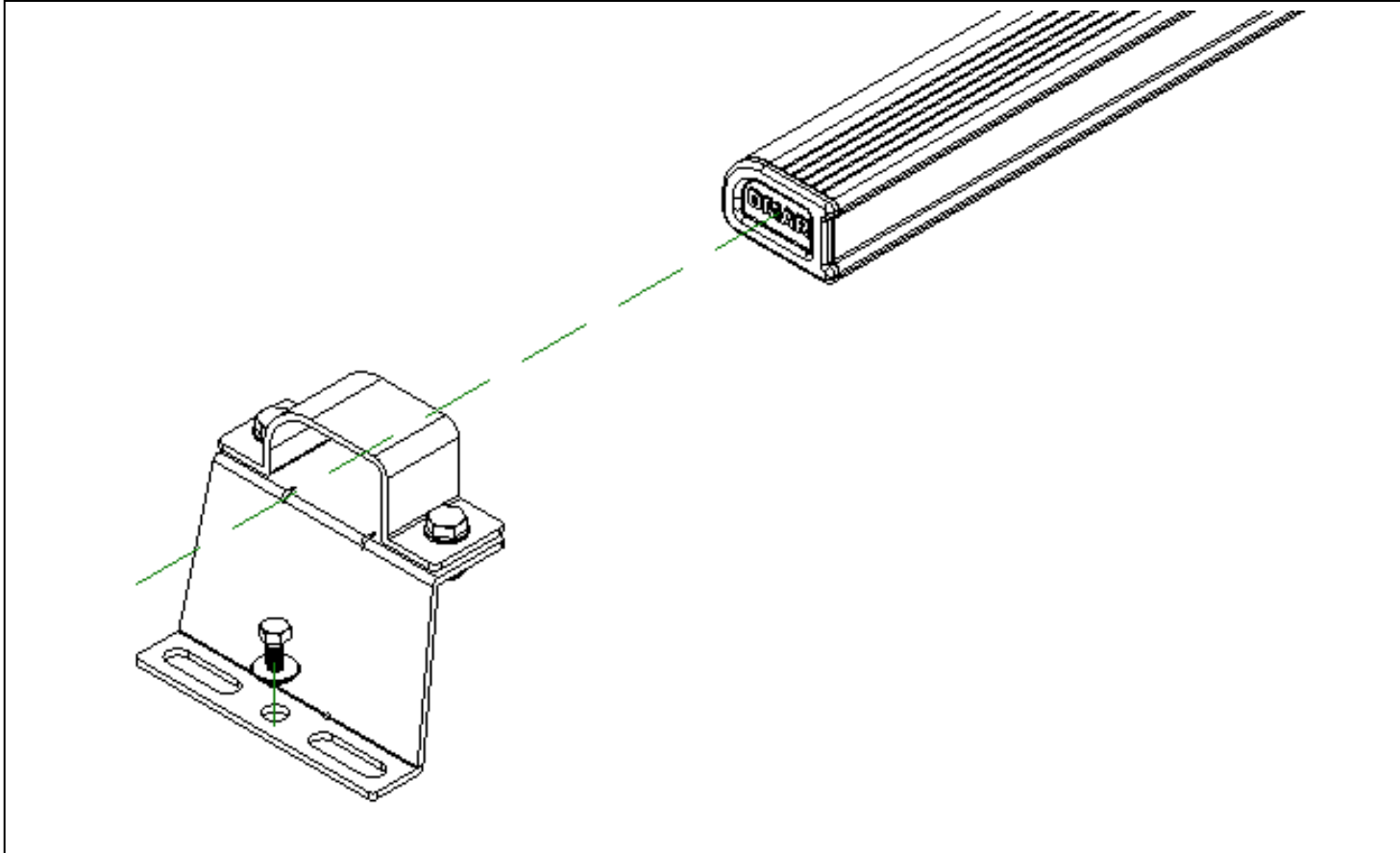

Once in position, tighten all fixings to **8Nm**.
Periodically check all fixings.



NOTES: Do not exceed vehicle manufacturers roof loading recommendations. Loads must be evenly distributed. All fixings and clamps need to be checked regularly for fatigue or wear and tightened or replaced when required. Paint damage to be touched up to prevent corrosion occurring. No liability is accepted by DEMAR for damage to vehicle or claims arising from use of roof rack. User must ensure all Health and Safety recommendations are complied.

